

www.ti.com

High Common-Mode Voltage DIFFERENCE AMPLIFIER

FEATURES

- COMMON-MODE INPUT RANGE:
 $\pm 200\text{V}$ ($V_S = \pm 15\text{V}$)
- PROTECTED INPUTS:
 $\pm 500\text{V}$ Common-Mode
 $\pm 500\text{V}$ Differential
- UNITY GAIN: 0.02% Gain Error max
- NONLINEARITY: 0.001% max
- CMRR: 86dB min

APPLICATIONS

- CURRENT MONITOR
- BATTERY CELL-VOLTAGE MONITOR
- GROUND BREAKER
- INPUT PROTECTION
- SIGNAL ACQUISITION IN NOISY ENVIRONMENTS
- FACTORY AUTOMATION

DESCRIPTION

The INA117 is a precision unity-gain difference amplifier with very high common-mode input voltage range. It is a single monolithic IC consisting of a precision op amp and integrated thin-film resistor network. It can accurately measure small differential voltages in the presence of common-mode signals up to $\pm 200\text{V}$. The INA117 inputs are protected from momentary common-mode or differential overloads up to $\pm 500\text{V}$.

In many applications, where galvanic isolation is not essential, the INA117 can replace isolation amplifiers. This can eliminate costly isolated input-side power supplies and their associated ripple, noise and quiescent current. The INA117's 0.001% nonlinearity and 200kHz bandwidth are superior to those of conventional isolation amplifiers.

The INA117 is available in 8-pin plastic mini-DIP and SO-8 surface-mount packages, specified for the -40°C to $+85^\circ\text{C}$ temperature range. The metal TO-99 models are available specified for the -40°C to $+85^\circ\text{C}$ and -55°C to $+125^\circ\text{C}$ temperature range.

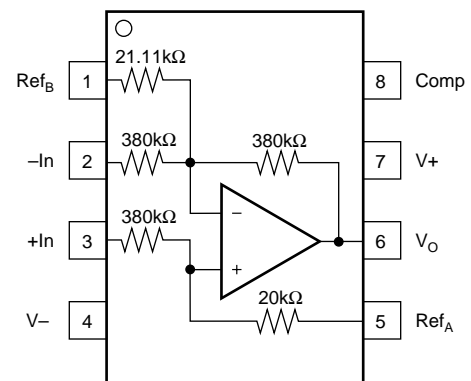

SPECIFICATIONS

At $T_A = +25^\circ\text{C}$, $V_S = \pm 15\text{V}$, unless otherwise noted.

PARAMETER	CONDITIONS	INA117AM, SM			INA117BM			INA117P, KU			UNITS
		MIN	TYP	MAX	MIN	TYP	MAX	MIN	TYP	MAX	
GAIN Initial ⁽¹⁾ Error vs Temperature Nonlinearity ⁽²⁾			1 0.01 2 0.0002			*			*	*	V/V % ppm/°C %
OUTPUT Rated Voltage Rated Current Impedance Current Limit Capacitive Load	$I_O = +20\text{mA}, -5\text{mA}$ $V_O = 10\text{V}$ To Common Stable Operation	10 +20, -5	12 0.01 +49, -13 1000		*	*		*	*		V mA Ω mA pF
INPUT Impedance Voltage Range Common-Mode Rejection ⁽³⁾ DC AC, 60Hz vs Temperature, DC AM, BM, P, KU SM	Differential Common-Mode Differential Common-Mode, Continuous $V_{CM} = 400\text{Vp-p}$ $T_A = T_{MIN}$ to T_{MAX}	 ± 10 ± 200 70 66 66 60	800 400 80 80 75 75			*	*	*	*	*	k Ω k Ω V V dB dB dB dB
OFFSET VOLTAGE Initial KU Grade (SO-8 Package) vs Temperature vs Supply vs Time	RTO ⁽⁴⁾ $T_A = T_{MIN}$ to T_{MAX} $V_S = \pm 5\text{V}$ to $\pm 18\text{V}$		120 8.5 90 200	1000 40		*	1000 40 *		*	* 600 *	μV μV $\mu\text{V}/^\circ\text{C}$ dB $\mu\text{V}/\text{mo}$
OUTPUT NOISE VOLTAGE $f_B = 0.01\text{Hz}$ to 10Hz $f_B = 10\text{kHz}$	RTO ⁽⁵⁾		25 550			*	*		*	*	$\mu\text{Vp-p}$ nV/ $\sqrt{\text{Hz}}$
DYNAMIC RESPONSE Gain Bandwidth, -3dB Full Power Bandwidth Slew Rate Settling Time: 0.1% 0.01% 0.01%	$V_O = 20\text{Vp-p}$ $V_O = 10\text{V}$ Step $V_O = 10\text{V}$ Step $V_{CM} = 10\text{V}$ Step, $V_{DIFF} = 0\text{V}$	30 2	200 2.6 6.5 10 4.5		*	*	*	*	*	*	kHz kHz V/ μs μs μs μs
POWER SUPPLY Rated Voltage Range Quiescent Current	Derated Performance $V_O = 0\text{V}$	± 5	± 15 1.5	± 18 2	*	*	*	*	*	*	V V mA
TEMPERATURE RANGE Specification: AM, BM, P, KU SM Operation Storage		-25 -55 -55 -65		+85 +125 +125 +150	*	*	*	-40 -40 -55		+85 +85 +125	°C °C °C °C

*Specification same as for INA117AM.

NOTES: (1) Connected as difference amplifier (see Figure 1). (2) Nonlinearity is the maximum peak deviation from the best-fit straight line as a percent of full-scale peak-to-peak output. (3) With zero source impedance (see discussion of common-mode rejection in Application Information section). (4) Includes effects of amplifier's input bias and offset currents. (5) Includes effects of amplifier's input current noise and thermal noise contribution of resistor network.

PIN CONFIGURATION

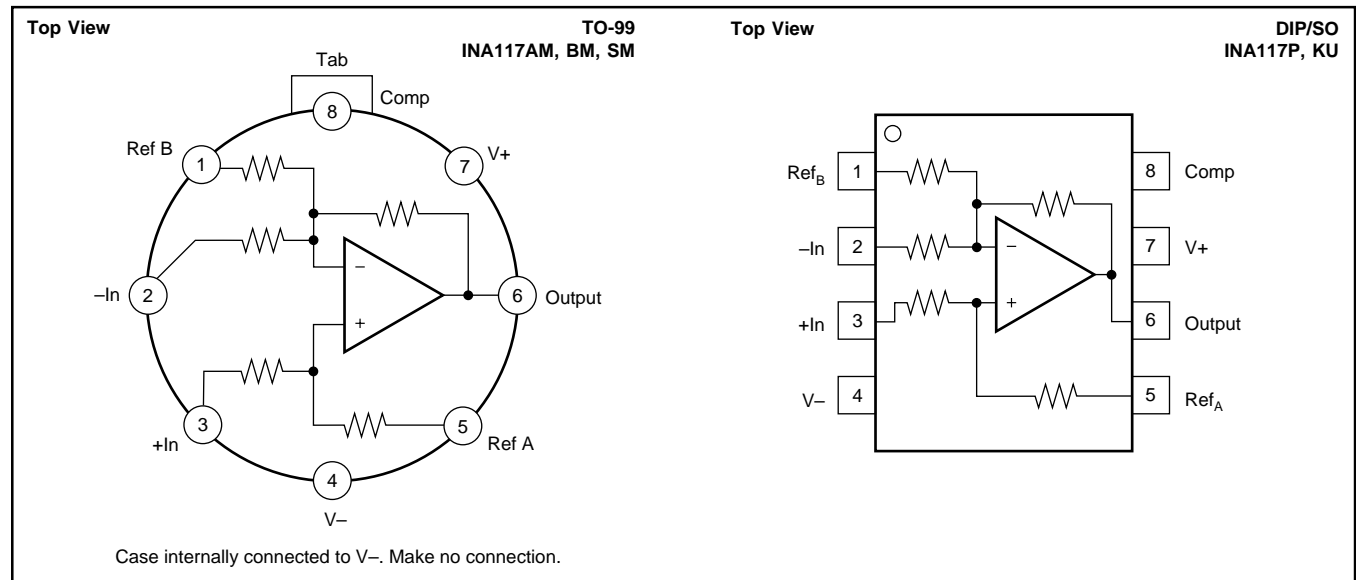

ABSOLUTE MAXIMUM RATINGS

Supply Voltage	±22V
Input Voltage Range, Continuous	±200V
Common-Mode and Differential, 10s	±500V
Operating Temperature	
M Metal TO-99	-55 to +125°C
P Plastic DIP and U SO-8	-40 to +85°C
Storage Temperature	
M Package	-65 to +150°C
P Plastic DIP and U SO-8	-55 to +125°C
Lead Temperature (soldering, 10s)	+300°C
Output Short Circuit to Common	Continuous



ELECTROSTATIC DISCHARGE SENSITIVITY

This integrated circuit can be damaged by ESD. Texas Instruments recommends that all integrated circuits be handled with appropriate precautions. Failure to observe proper handling and installation procedures can cause damage.

ESD damage can range from subtle performance degradation to complete device failure. Precision integrated circuits may be more susceptible to damage because very small parametric changes could cause the device not to meet its published specifications.

PACKAGE/ORDERING INFORMATION

PRODUCT	PACKAGE	PACKAGE DRAWING NUMBER	SPECIFIED TEMPERATURE RANGE	PACKAGE MARKING	ORDERING NUMBER ⁽¹⁾	TRANSPORT MEDIA
INA117P	DIP-8	006	-40°C to +85°C	INA117P	INA117P	Rails
INA117KU	SO-8 Surface-Mount	182	"	INA117KU	INA117KU	Rails
"	"	"	"	"	INA117KU/2K5	Tape and Reel
INA117AM	TO-99 Metal	001	-25°C to +85°C	INA117AM	INA117AM	Rails
INA117BM	"	"	"	INA117BM	INA117BM	Rails
INA117SM	"	"	-55°C to +125°C	INA117SM	INA117SM	Rails

NOTE: (1) Models with a slash (/) are available only in Tape and Reel in the quantities indicated (e.g., /2K5 indicates 2500 devices per reel). Ordering 2500 pieces of "INA117KU/2K5" will get a single 2500-piece Tape and Reel.

TYPICAL PERFORMANCE CURVES

At $T_A = +25^\circ\text{C}$, $V_S = \pm 15\text{V}$, unless otherwise noted.

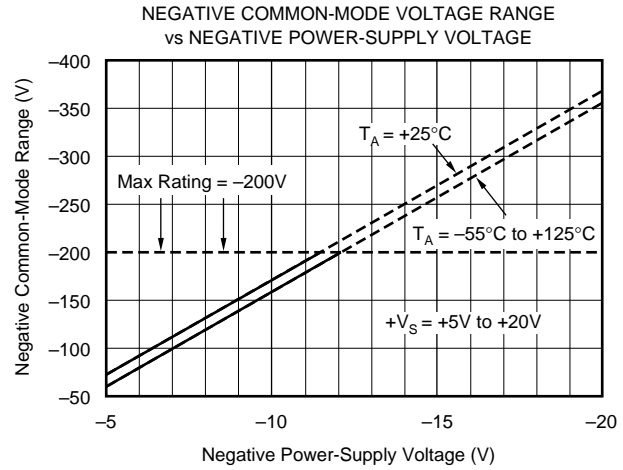
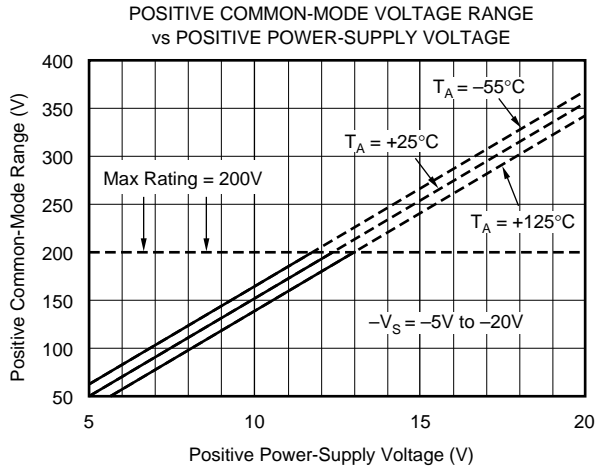
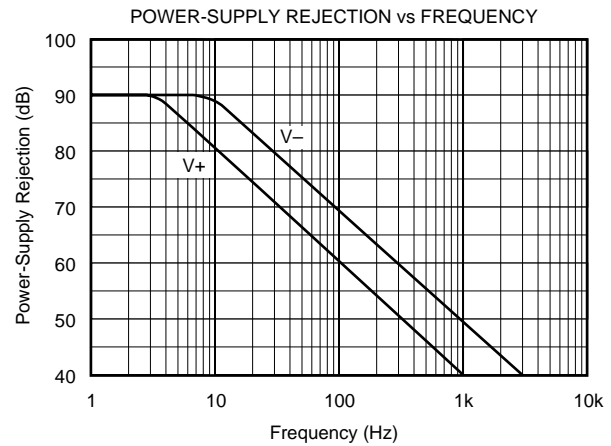
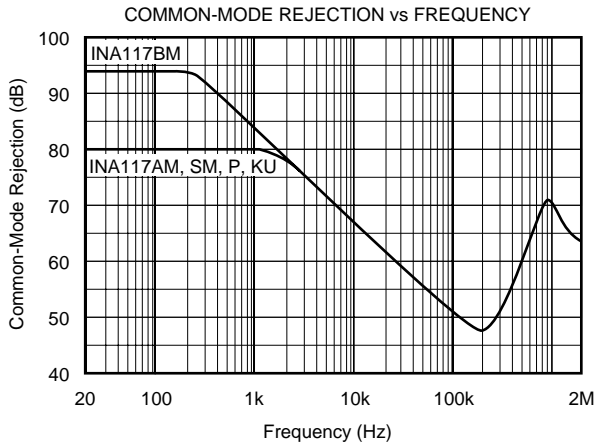

TYPICAL PERFORMANCE CURVES (Cont.)

At $T_A = +25^\circ\text{C}$, $V_S = \pm 15\text{V}$, unless otherwise noted.

SMALL SIGNAL STEP RESPONSE
 $C_L = 0$

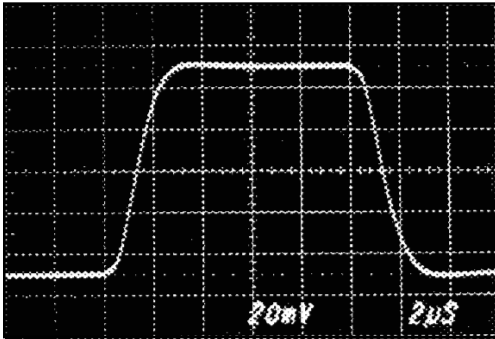

SMALL SIGNAL STEP RESPONSE
 $C_L = 1000\text{pF}$

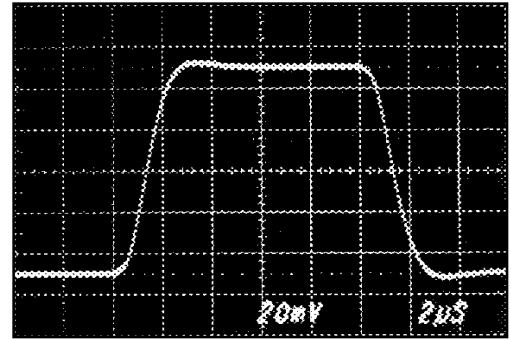

LARGE SIGNAL STEP RESPONSE

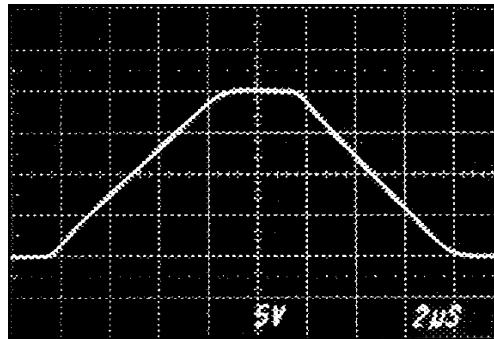

APPLICATION INFORMATION

Figure 1 shows the basic connections required for operation.

Applications with noisy or high-impedance power-supply lines may require decoupling capacitors close to the device pins.

The output voltage is equal to the differential input voltage between pins 2 and 3. The common mode input voltage is rejected.

Internal circuitry connected to the compensation pin 8 cancels the parasitic distributed capacitance between the feedback resistor, R_2 , and the IC substrate. For specified dynamic performance, pin 8 should be grounded or connected through a $0.1\mu\text{F}$ capacitor to an AC ground such as V_+ .

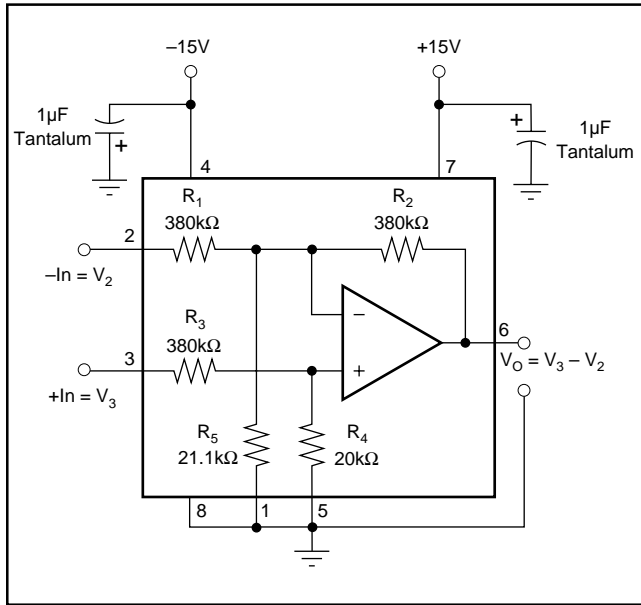

FIGURE 1. Basic Power and Signal Connections.

COMMON-MODE REJECTION

Common-mode rejection (CMR) of the INA117 is dependent on the input resistor network, which is laser-trimmed for accurate ratio matching. To maintain high CMR, it is important to have low source impedances driving the two inputs. A 75Ω resistance in series with pin 2 or 3 will decrease CMR from 86dB to 72dB.

Resistance in series with the reference pins will also degrade CMR. A 4Ω resistance in series with pin 1 or 5 will decrease CMRR from 86dB to 72dB.

Most applications do not require trimming. Figures 2 and 3 show optional circuits that may be used for trimming offset voltage and common-mode rejection.

TRANSFER FUNCTION

Most applications use the INA117 as a simple unity-gain difference amplifier. The transfer function is:

$$V_O = V_3 - V_2$$

V_3 and V_2 are the voltages at pins 3 and 2.

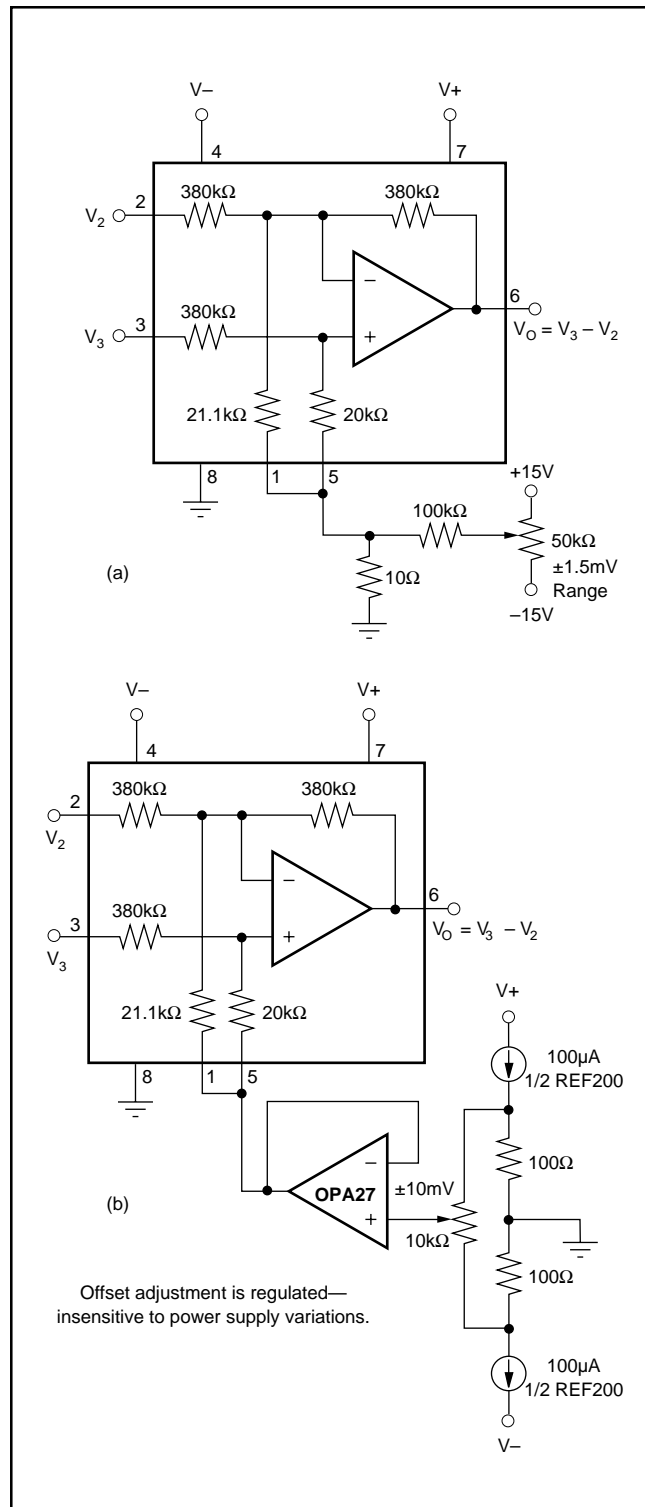

FIGURE 2. Offset Voltage Trim Circuits.

Some applications, however, apply voltages to the reference terminals (pins 1 and 5). A more complete transfer function is:

$$V_O = V_3 - V_2 + 19 \cdot V_5 - 18 \cdot V_1$$

V_5 and V_1 are the voltages at pins 5 and 1.

MEASURING CURRENT

The INA117 can be used to measure a current by sensing the voltage drop across a series resistor, R_S . Figure 4 shows the INA117 used to measure the supply currents of a device under test. The circuit in Figure 5 measures the output current of a power supply. If the power supply has a sense connection, it can be connected to the output side of R_S to eliminate the voltage-drop error. Another common application is current-to-voltage conversion, as shown in Figure 6.

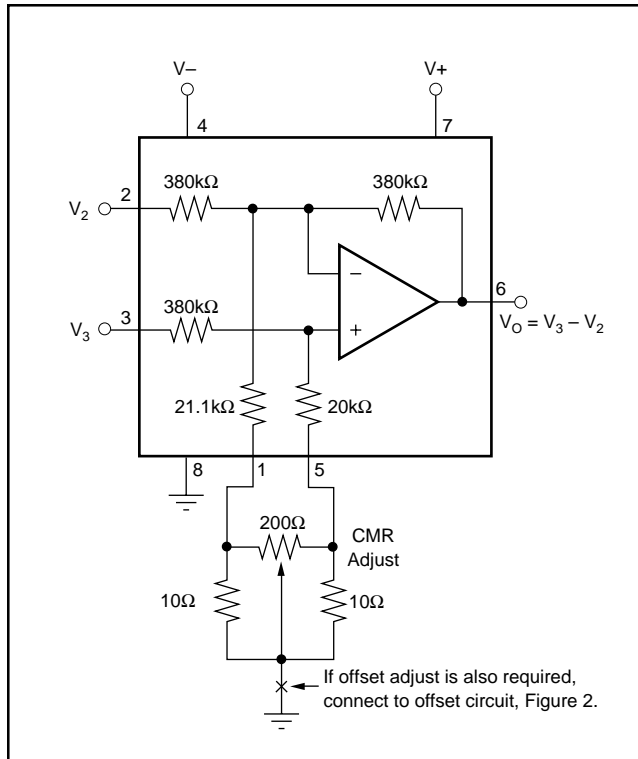

FIGURE 3. CMR Trim Circuit.

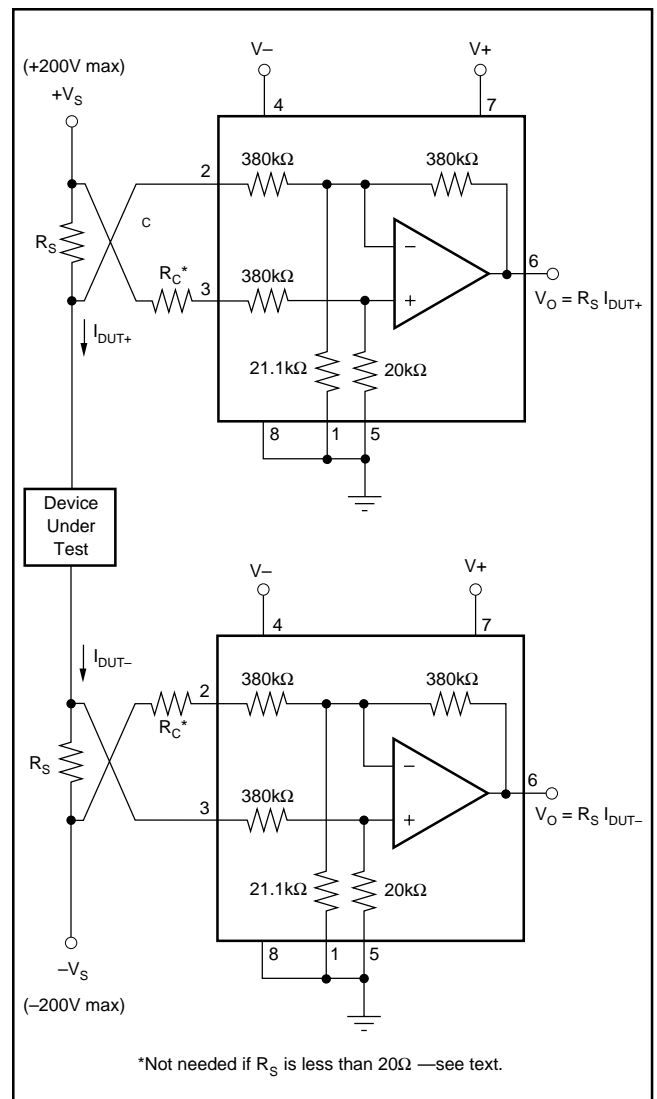

FIGURE 4. Measuring Supply Currents of Device Under Test.

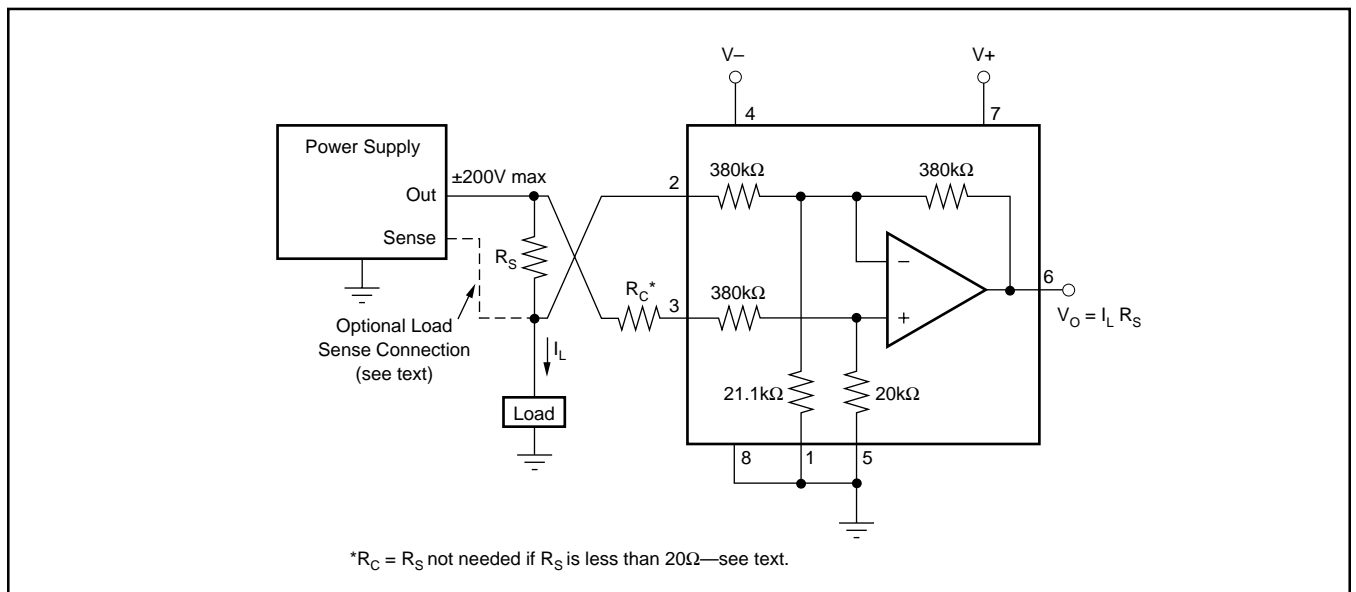

FIGURE 5. Measuring Power Supply Output Current.

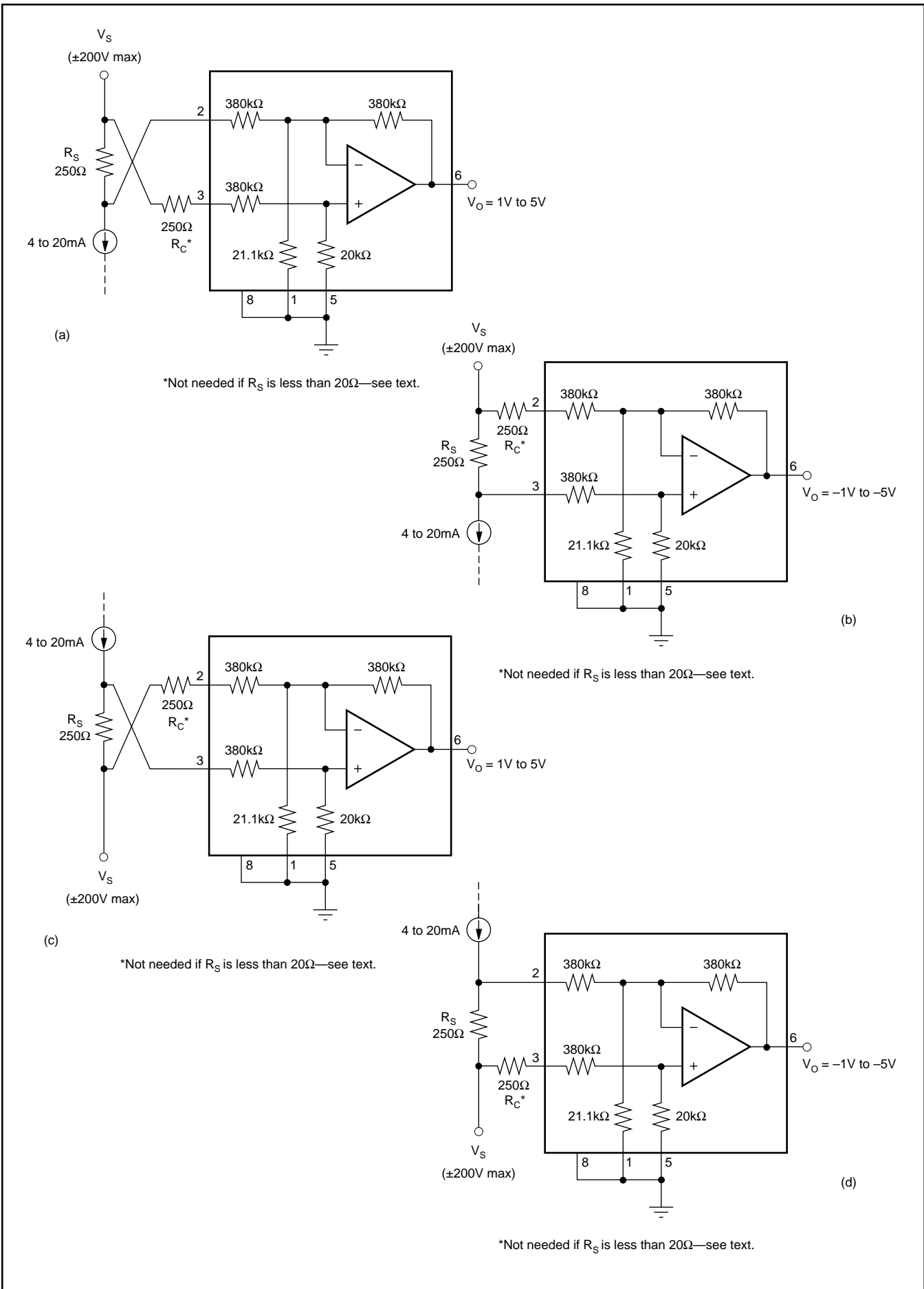

FIGURE 6. Current to Voltage Converter.

In all cases, the sense resistor imbalances the input resistor matching of the INA117, degrading its CMR. Also, the input impedance of the INA117 loads R_S , causing gain error in the voltage-to-current conversion. Both of these errors can be easily corrected.

The CMR error can be corrected with the addition of a compensation resistor, R_C , equal in value to R_S as shown in Figures 4, 5, and 6. If R_S is less than 20Ω , the degradation in CMR is negligible and R_C can be omitted. If R_S is larger than approximately $2k\Omega$, trimming R_C may be required to achieve greater than 86dB CMR. This is because the actual INA117 input impedances have 1% typical mismatch.

If R_S is more than approximately 100Ω , the gain error will be greater than the 0.02% specification of the INA117. This gain error can be corrected by slightly increasing the value of R_S . The corrected value, R_S' , can be calculated by:

$$R_S' = \frac{R_S \cdot 380k\Omega}{380k\Omega - R_S}$$

Example: For a 1V/mA transfer function, the nominal, uncorrected value for R_S would be $1k\Omega$. A slightly larger value, $R_S' = 1002.6\Omega$, compensates for the gain error due to loading.

The $380k\Omega$ term in the equation for R_S' has a tolerance of $\pm 25\%$, so sense resistors above approximately 400Ω may require trimming to achieve gain accuracy better than 0.02%.

Of course, if a buffer amplifier is added as shown in Figure 7, both inputs see a low source impedance, and the sense resistor is not loaded. As a result, there is no gain error or CMR degradation. The buffer amplifier can operate as a unity gain buffer or as an amplifier with non-inverting gain. Gain added ahead of the INA117 improves both CMR and signal-to-noise. Added gain also allows a lower voltage drop across the sense resistor. The OPA1013 is a good choice for the buffer amplifier since both its input and output can swing close to its negative power supply.

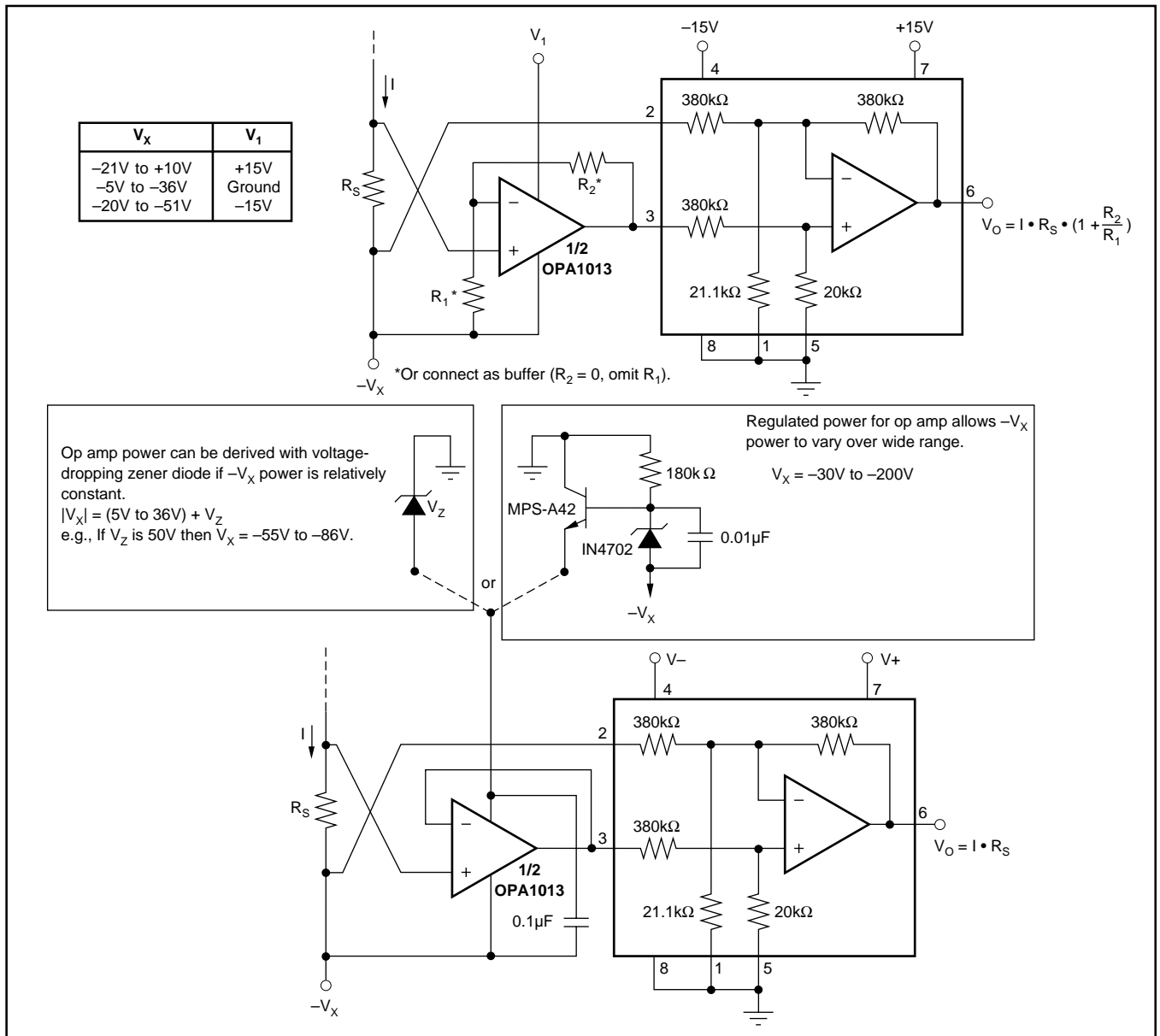

FIGURE 7. Current Sensing with Input Buffer.

Figure 8 shows very high input impedance buffer used to measure low leakage currents. Here, the buffer op amp is powered with an isolated, split-voltage power supply. Using an isolated power supply allows full $\pm 200\text{V}$ common-mode input range.

NOISE PERFORMANCE

The noise performance of the INA117 is dominated by the internal resistor network. The thermal or Johnson noise of

these resistors produces approximately $550\text{nV}/\sqrt{\text{Hz}}$ noise. The internal op amp contributes virtually no excess noise at frequencies above 100Hz.

Many applications may be satisfied with less than the full 200kHz bandwidth of the INA117. In these cases, the noise can be reduced with a low-pass filter on the output. The two-pole filter shown in Figure 9 limits bandwidth to 1kHz and reduces noise by more than 15:1. Since the INA117 has a 1/f noise corner frequency of approximately 100Hz, a cutoff frequency below 100Hz will not further reduce noise.

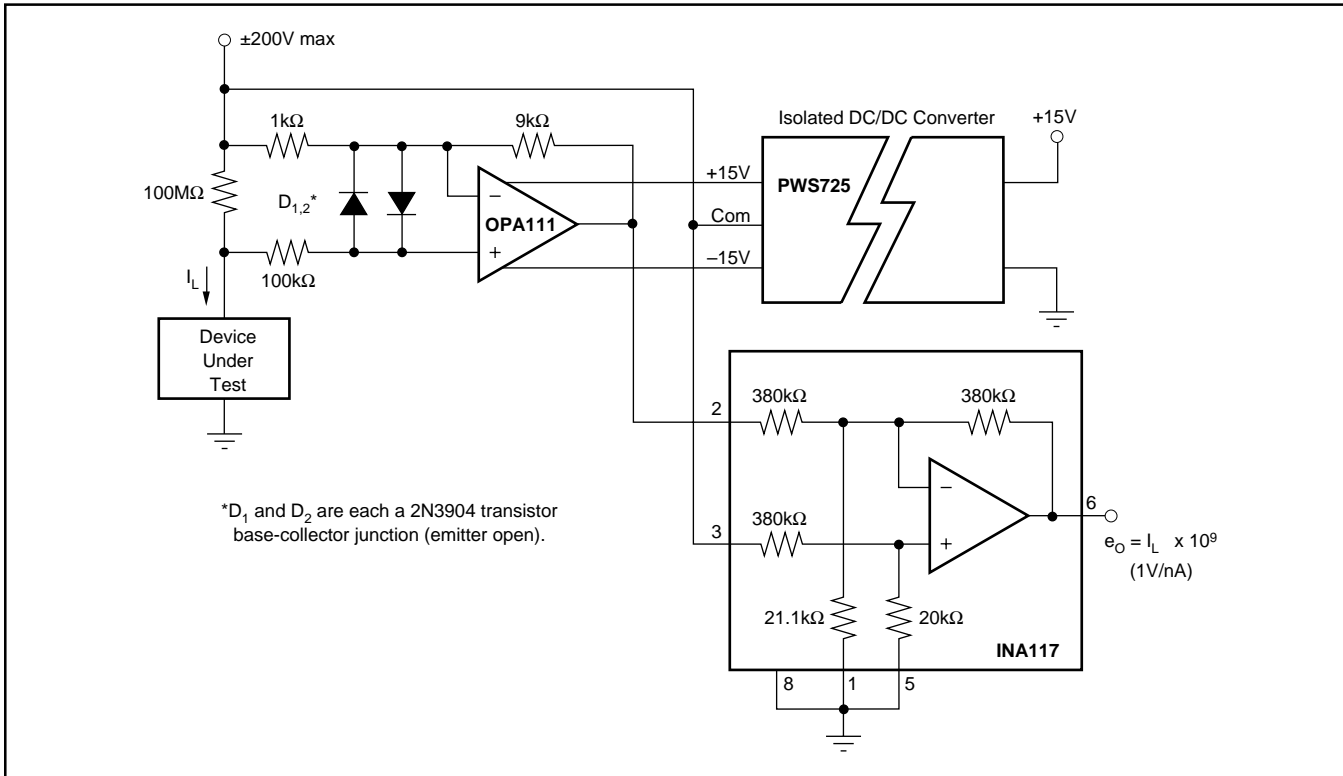

FIGURE 8. Leakage Current Measurement Circuit.

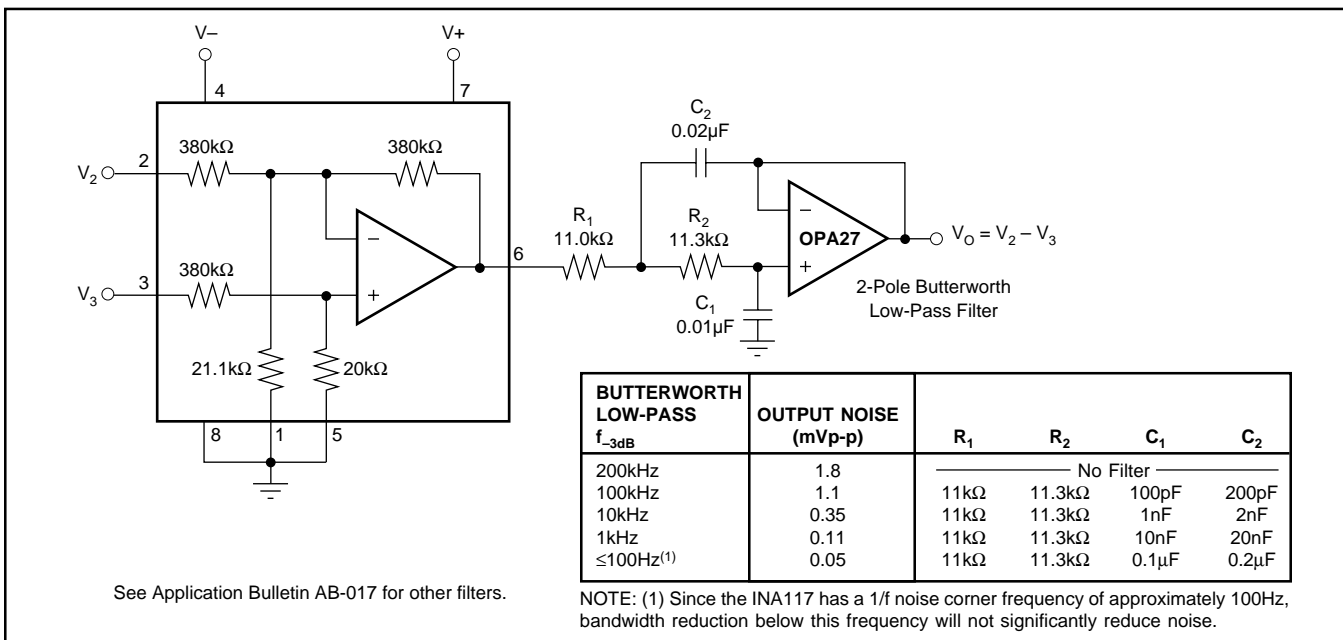

FIGURE 9. Output Filter for Noise Reduction.

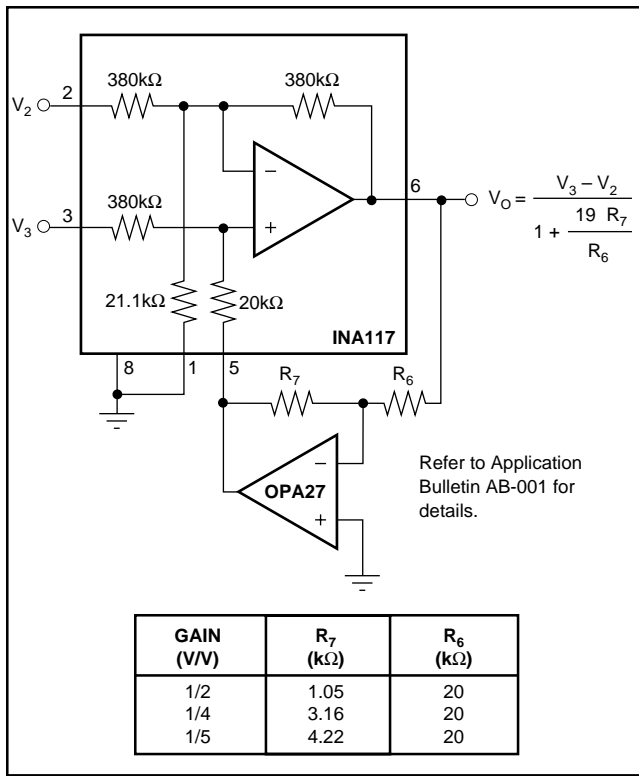

FIGURE 10. Reducing Differential Gain.

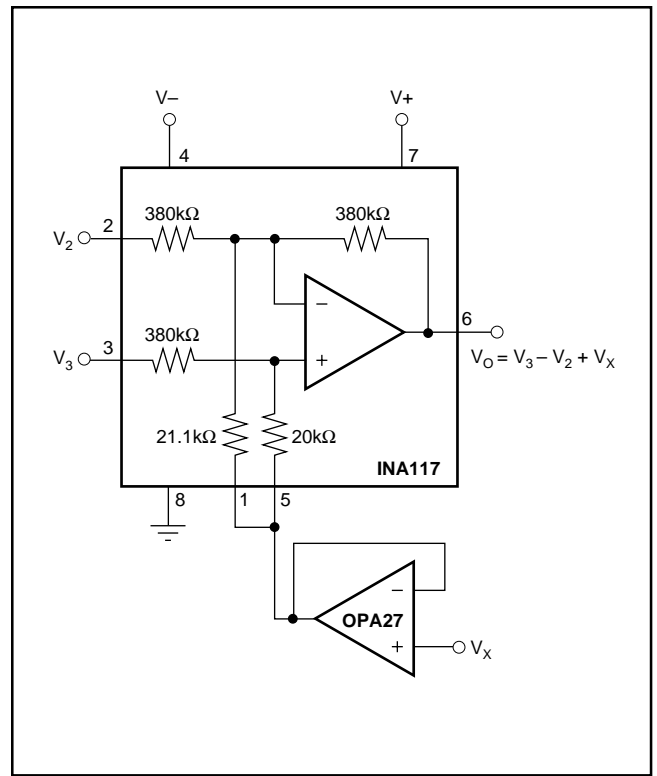

FIGURE 11. Summing V_X in Output.

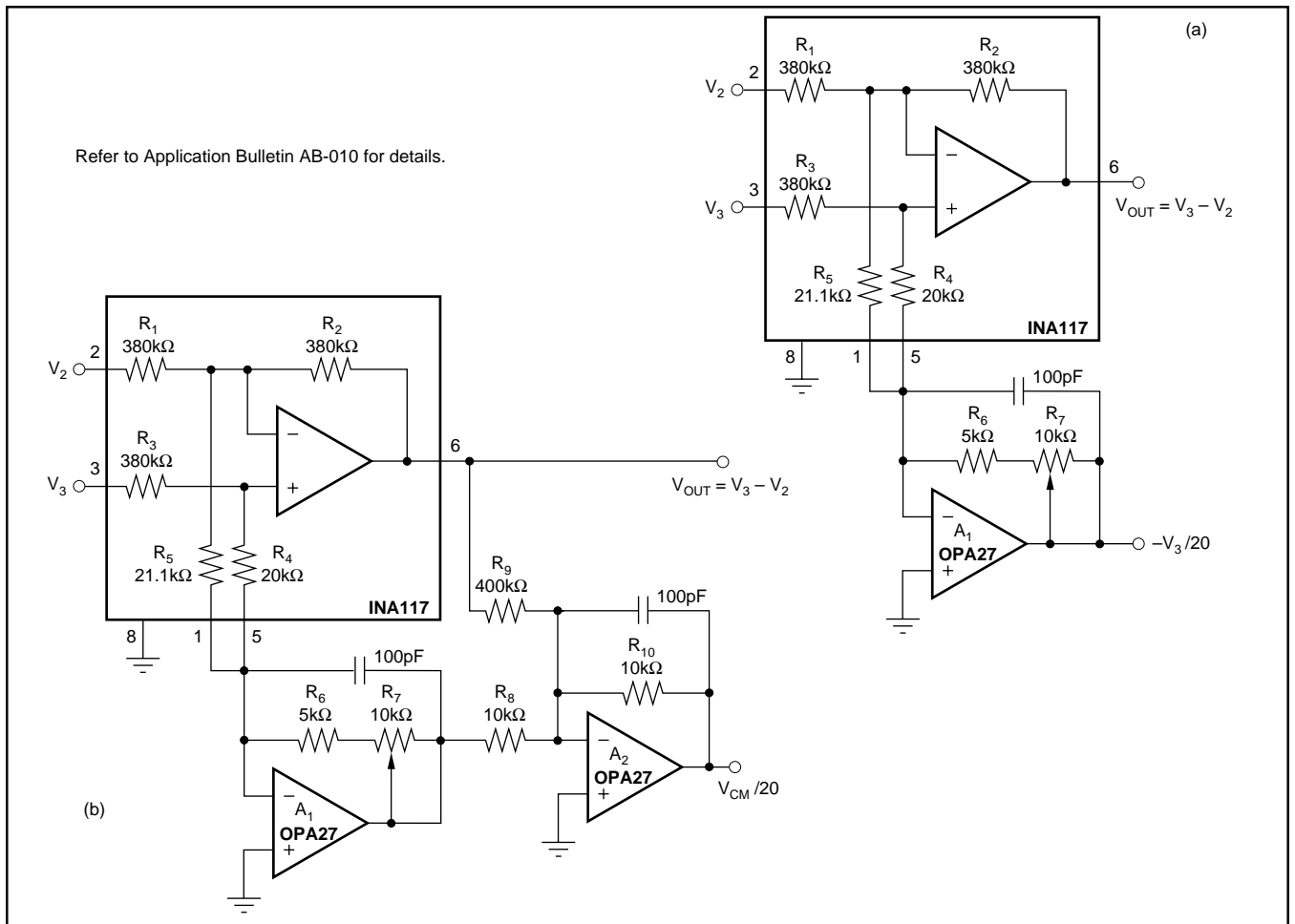

FIGURE 12. Common-Mode Voltage Monitoring.

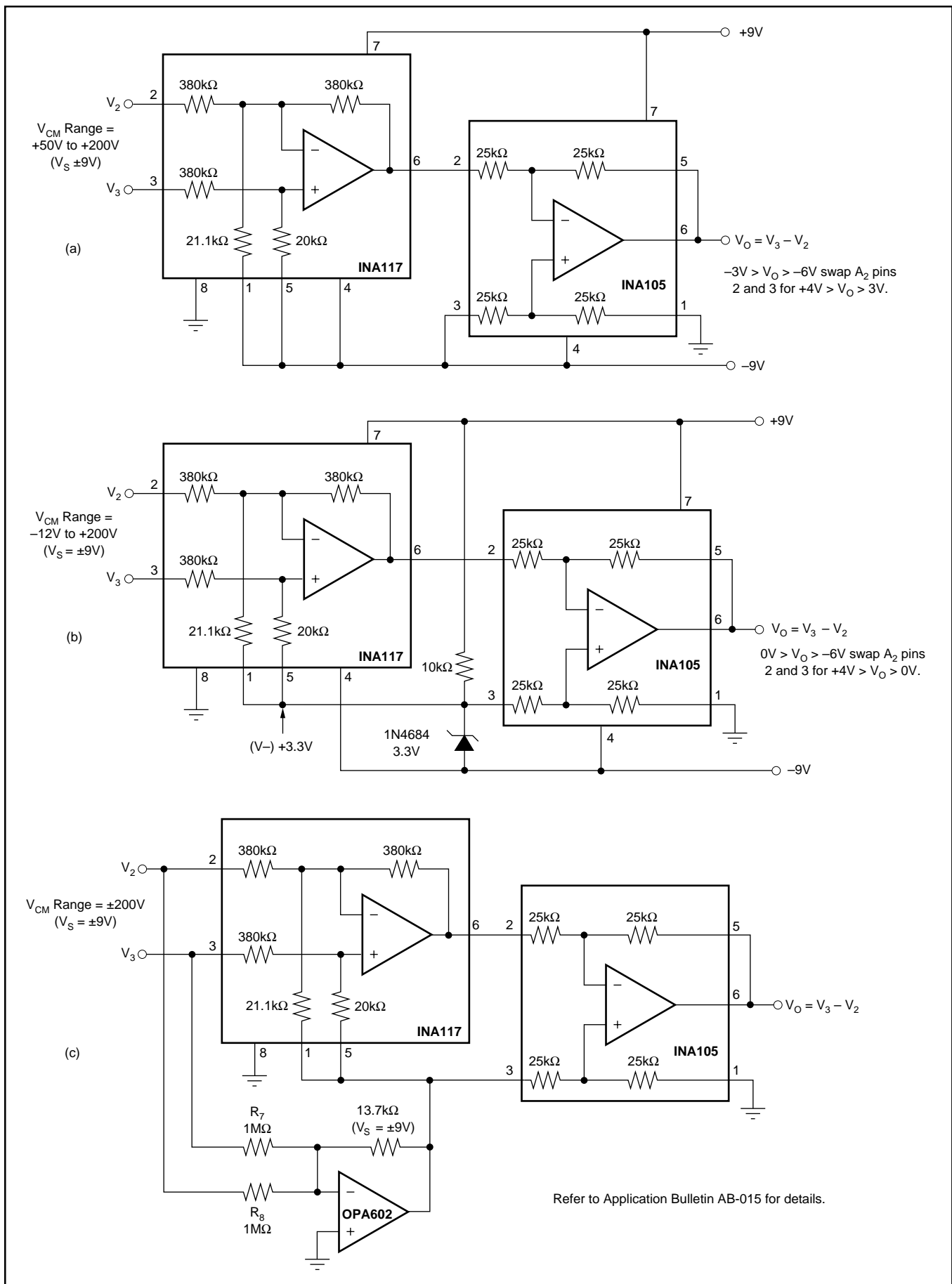

FIGURE 13. Offsetting or Boosting Common-Mode Voltage Range for Reduced Power-Supply Voltage Operation.

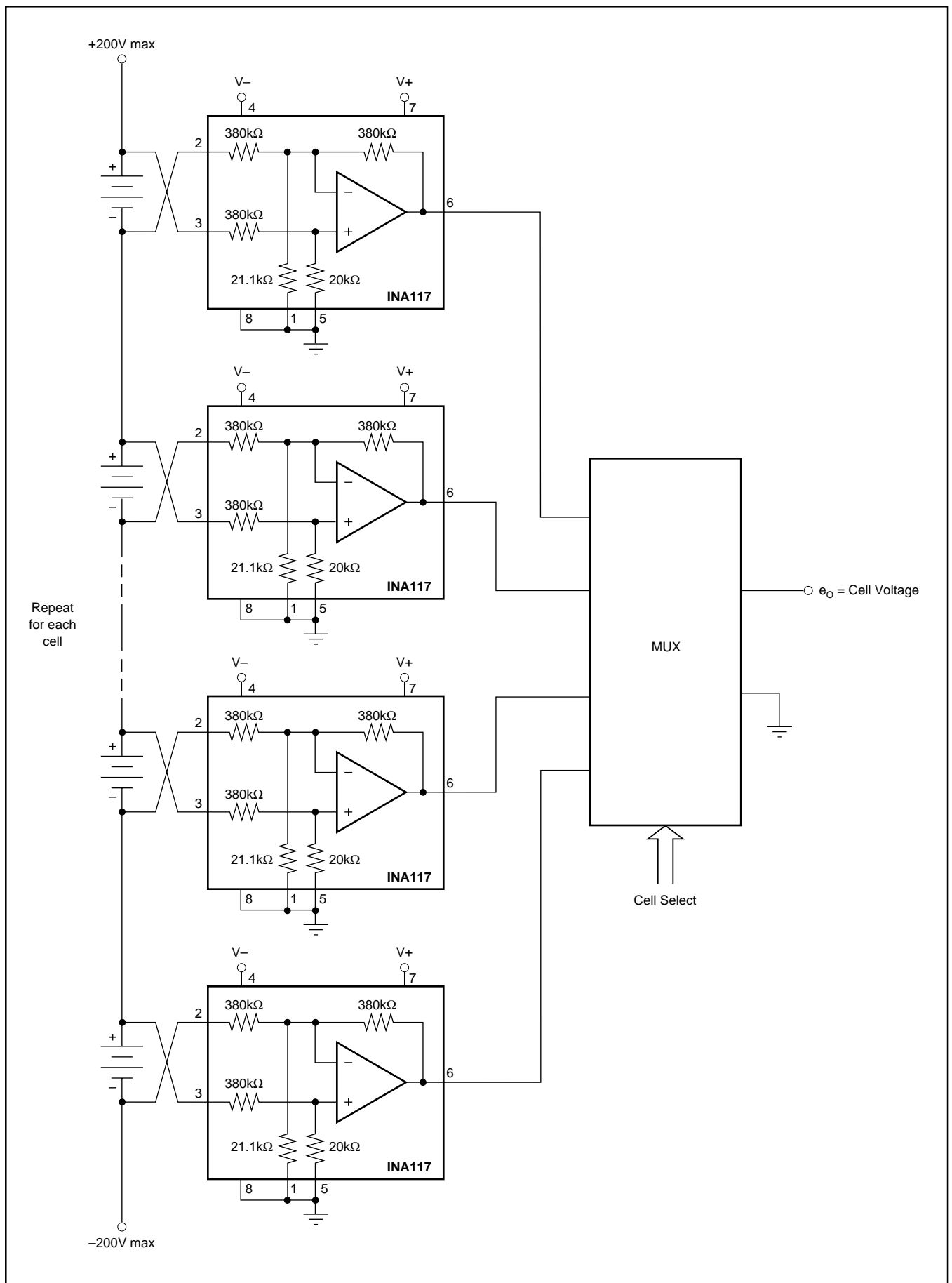

FIGURE 14. Battery Cell Voltage Monitor.

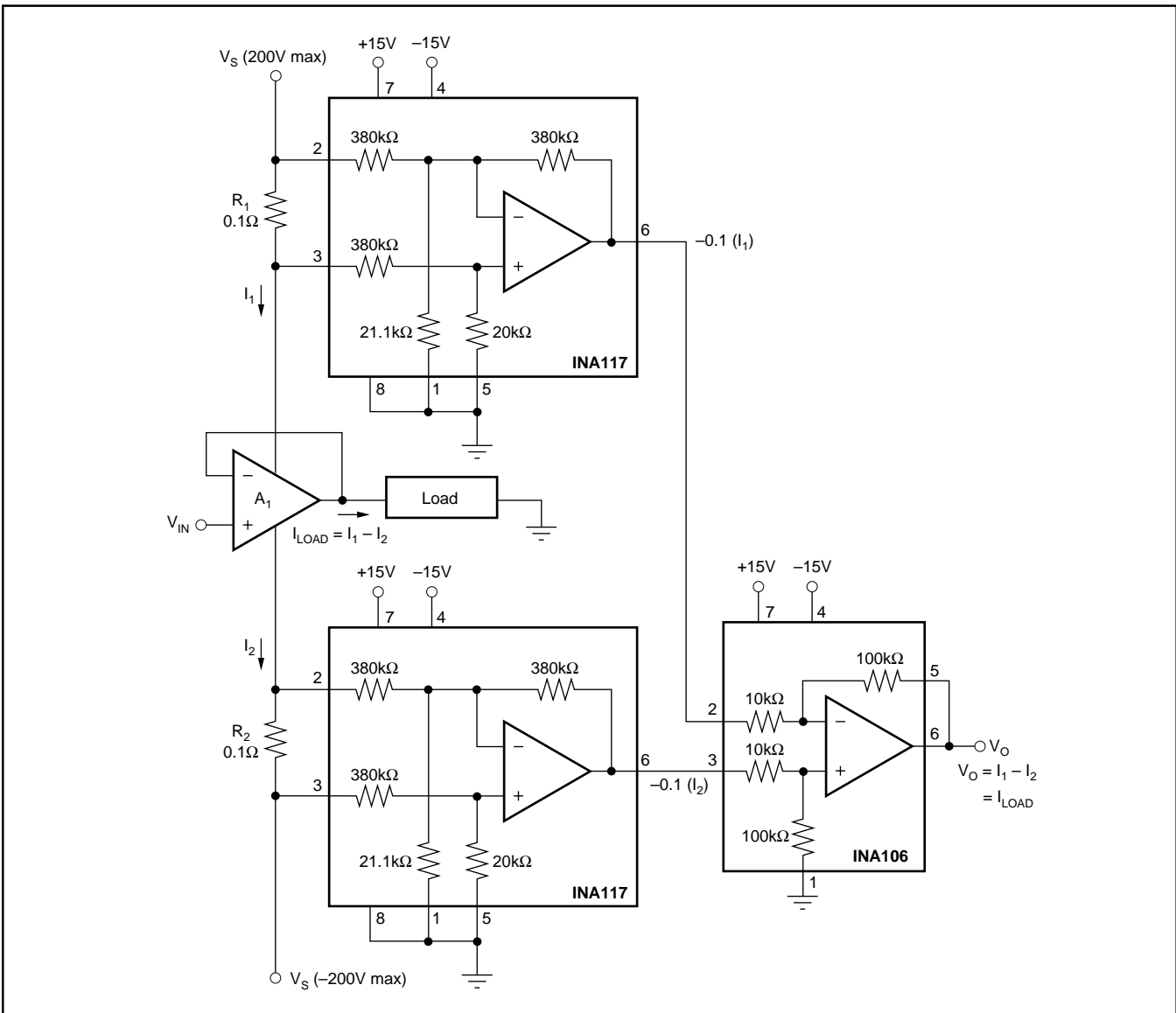

FIGURE 15. Measuring Amplifier Load Current.

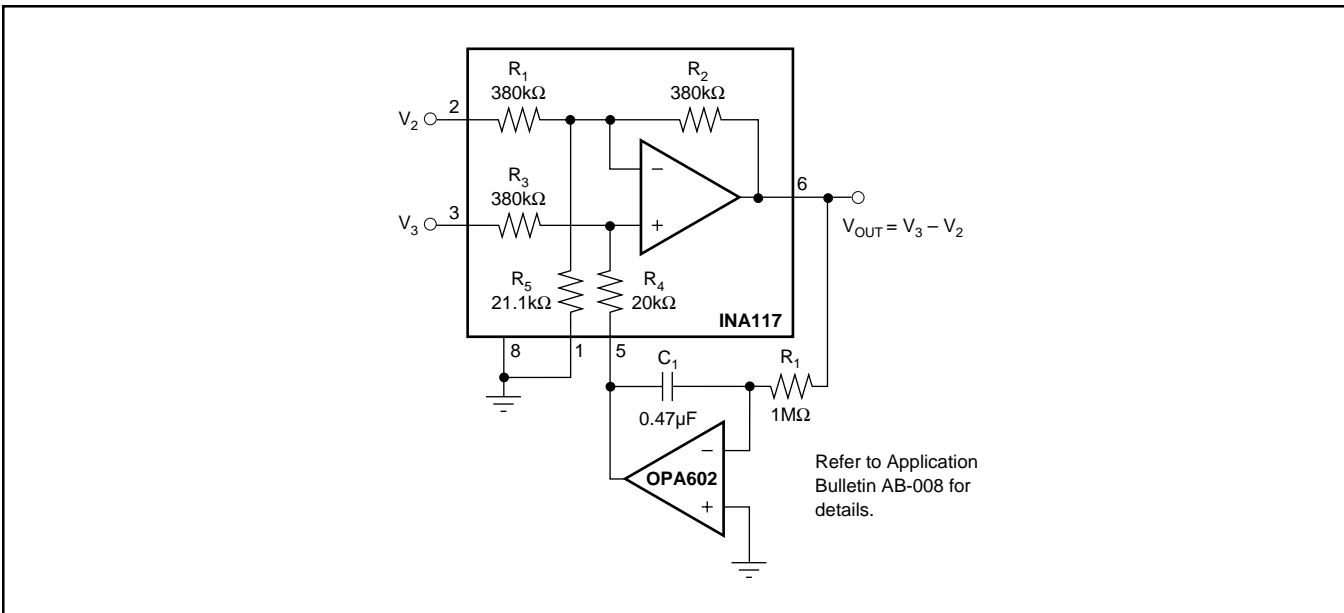

FIGURE 16. AC-Coupled INA117.

IMPORTANT NOTICE

Texas Instruments and its subsidiaries (TI) reserve the right to make changes to their products or to discontinue any product or service without notice, and advise customers to obtain the latest version of relevant information to verify, before placing orders, that information being relied on is current and complete. All products are sold subject to the terms and conditions of sale supplied at the time of order acknowledgment, including those pertaining to warranty, patent infringement, and limitation of liability.

TI warrants performance of its products to the specifications applicable at the time of sale in accordance with TI's standard warranty. Testing and other quality control techniques are utilized to the extent TI deems necessary to support this warranty. Specific testing of all parameters of each device is not necessarily performed, except those mandated by government requirements.

Customers are responsible for their applications using TI components.

In order to minimize risks associated with the customer's applications, adequate design and operating safeguards must be provided by the customer to minimize inherent or procedural hazards.

TI assumes no liability for applications assistance or customer product design. TI does not warrant or represent that any license, either express or implied, is granted under any patent right, copyright, mask work right, or other intellectual property right of TI covering or relating to any combination, machine, or process in which such products or services might be or are used. TI's publication of information regarding any third party's products or services does not constitute TI's approval, license, warranty or endorsement thereof.

Reproduction of information in TI data books or data sheets is permissible only if reproduction is without alteration and is accompanied by all associated warranties, conditions, limitations and notices. Representation or reproduction of this information with alteration voids all warranties provided for an associated TI product or service, is an unfair and deceptive business practice, and TI is not responsible nor liable for any such use.

Resale of TI's products or services with statements different from or beyond the parameters stated by TI for that product or service voids all express and any implied warranties for the associated TI product or service, is an unfair and deceptive business practice, and TI is not responsible nor liable for any such use.

Also see: [Standard Terms and Conditions of Sale for Semiconductor Products](http://www.ti.com/sc/docs/stdterms.htm). www.ti.com/sc/docs/stdterms.htm

Mailing Address:

Texas Instruments
Post Office Box 655303
Dallas, Texas 75265